

HZ-3150A
Transformer DC Resistance Tester

USER MANUAL

Dear user:

Thank you for choosing HZ-3150A Transformer DC Resistance Tester.

We hope that this instrument can make your work easier and more enjoyable, so that you can get the feeling of office automation in the test and analysis work.

Before using the instrument, please read this manual, and operate and maintain the instrument according to the manual to prolong its service life. "Just a light press, the test will be completed automatically" is the operating characteristics of this instrument.

If you are satisfied with this instrument, please tell your colleagues; if you are not satisfied with this instrument, please call (0312) 6775656 to tell you to serve you at all times-Baoding Huazheng Electric Manufacturing Co., Ltd., our company will definitely make you satisfied !

Contents

I. Introduction.....	1
II. Safety Measure.....	1
III. Configuration.....	1
IV. Technical Data.....	2
V. Presentation Of The System.....	2
VI. Test And Operating.....	3
VII. Caution.....	5
VIII. Guarantee and After Sales Service.....	5
IX. Packing List.....	6

I. Introduction

The DC resistance is the transformer's semi-finished product, finished product test, installation, commissioning test, and electric part prevention test necessary test project, the transformer coil can effectively find the device welding, connecting parts loose, missing unit, disconnection, and other manufacturing default and other hidden danger occurred after operation.

The DC Resistance transformer to meet fast measurement requirement, we developed HZ-3150 DC Resistance Tester. The instrument is a new powerful technology, small size, light weight, high output current and other characteristics.

The device is controlled by the microcontroller, with a high degree of automation, automatic discharge functions. It is a test instrument of high precision, simple, direct way to achieve fast transformer measurement.

II. Safety Measure

1. Before using this equipment you must carefully read the manual.
2. The equipment operator should have electric general knowledge .
3. Avoid putting the equipment in the contact of the rain, corrosive gas, dust, high temperature, direct sunlight, and other places.
4. Severe vibration has to be avoiding for gauges.
5. Only an expert must maintain and adjust the equipment .
6. After the test, the user must wait till the discharge alarm stopped before switching off the device, and plugging off the test cables.
7. To measure no-load regulating transformers, the user has to wait till the discharge instructions alarm stops before switching stalls.
8. During testing, do not move the testing clamp and cables.

III. Configuration

1. The device output current high, light weight.
2. Has a complete circuit protection, reliable.
3. Vertical chassis structure, easy operating on field.
4. Discharge alarm, discharge indicator clear, reduces misuse.

SEL: Setup the current after the tester was reset. press the key for 1-2s to print

VI. Test And Operating

1. Connection : Connect the testing product to the device through test terminal, joint firm; meanwhile insure a good connection of the earthing wire.

A. Direct measurement connection (see picture 2) :

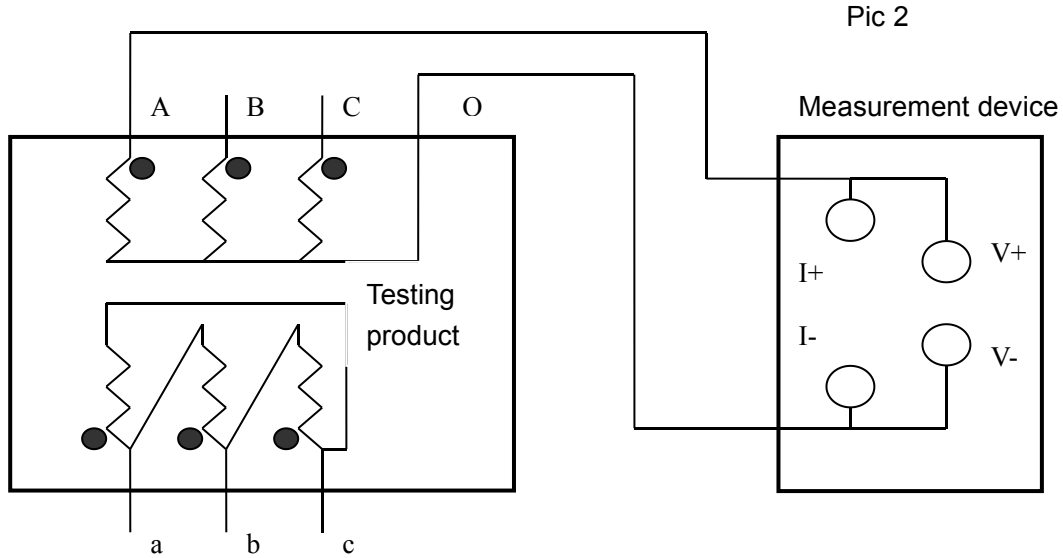

B. magnetic assisted connections see picture 3 to 5 (suitable $Y_{(N)}$ -d-11junction group)

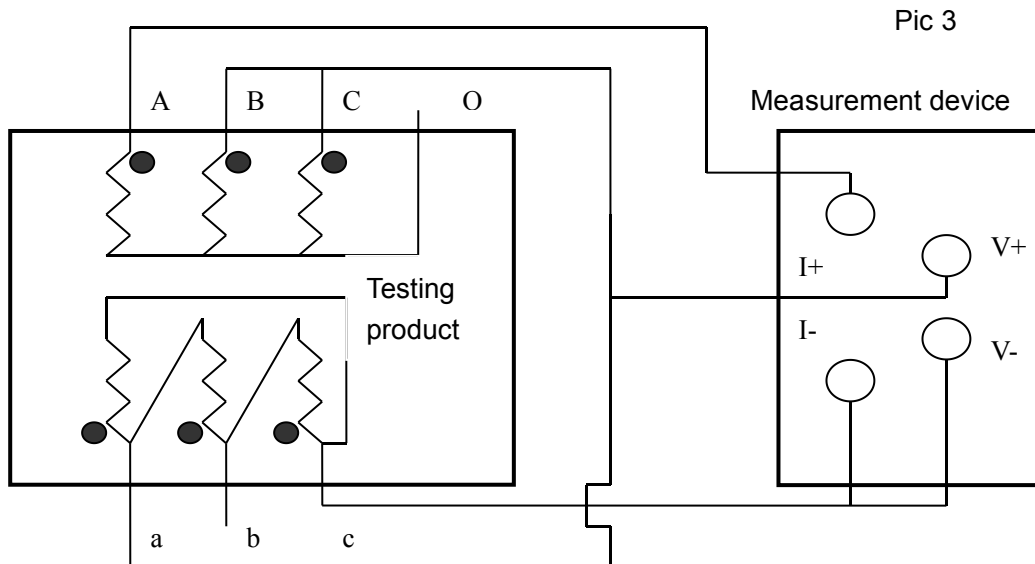

Pic 4

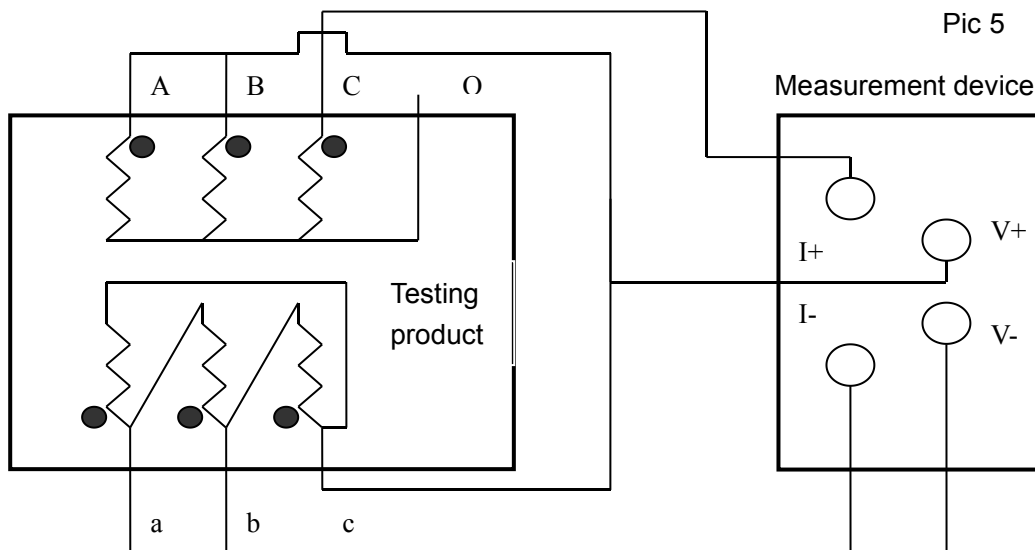
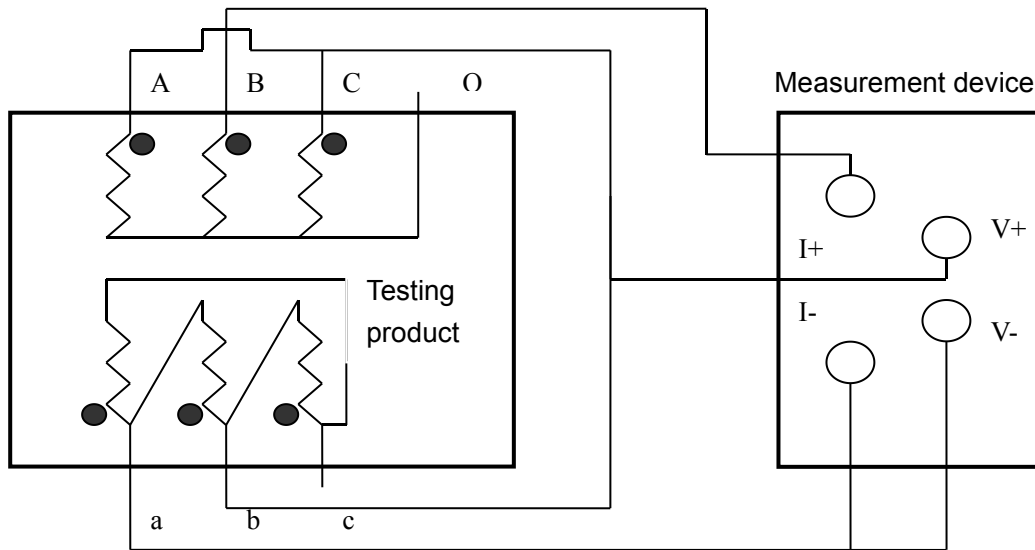

Pic 5

Picture 3, 4, 5 respectively measure low voltage Rac, Rba, Rcb connection

2. **Current options:** open the power switch ("I" opens the switch, "O" closes it) meanwhile all the current values will be displayed on the screen, then user can select key for the test products' current preferences, each time the user press a key, the cursor will roll between the current value of <5mA, 1A, 5A, 10A, 30A.

3. **Testing:**

Time	
Data	
Current	10A

after selecting the current, press START UP to start the test; meanwhile, the gauge will indicate all the selected current values. When press START UP, few seconds later, it will display "CHARGING", when it displays "TESTING" that means the "CHARGING" has been completed. Few seconds after accessing the TEST STATUS it will show the measured resistance values. (On-screen it will display the selected current value with all the measured resistance values, $I =$ " " A; $R =$ " " m Ω / Ω).

4. **After the test:** press "RESET", and winding device will disconnect the power supply, discharge, alarm, Ammeters back to zero, then restore status, and after the discharge alarm, re-connection, proceed the next test or unplug the test cable and end the measurement.

VII. Caution

1. During the no-load measurement, before resetting the transformer invert load, wait the discharge alarm stops, before switching the tap.
2. Wait till the discharge alarm stops before reconnecting wires
3. Before selecting the current, refer to the technical instruction range, don't exceed or be lower than the use range. When over passing the range, because the current doesn't reach the preset value, the device will stay in "CHARGING" status. In case of lower range, it will display "CURRENT VERY LOW", when the two status appear START UP the range, select the suitable current and carry testing.
4. When using the magnetic assisting method check carefully the range. Because of the high voltage winding, two parallel and one series, on the device test the circuit adding 1.5 times the high voltage winding resistance, make the conversion when selecting the range; If over passing the range, the output current can not reach the setting value or it is not stable.
5. On the magnetic assisting method three cables on the short taps have to be disconnected after discharge, it may be residual current and tinder discharge, which is normal.

VIII. Guarantee and After Sales Service

The company repairs any problem due to the quality of the equipment for one year from the date you purchase our product.

We provide lifelong maintenance and technology service. If there are abnormalities or faults occur, please timely contact with us, and then we will arrange convenient and fast disposal and field service.

IX. Packing List

No.	Item	Qty
1	Main engine	1
2	Red test line	1
3	Black test line	1
4	Power line	1
5	Ground lead	1
6	Fuse pipe	2
7	Print paper	1
8	Test sample (Standard resistance)	1
9	Serial port line	1