

# **HZ-2000B**

## **Transformer Tan Delta Tester**



Dear user:

Thank you for choosing HZ-2000B Transformer Tan Delta Tester.

We hope that this instrument can make your work easier and more enjoyable, so that you can get the feeling of office automation in the test and analysis work.

Before using the instrument, please read this manual, and operate and maintain the instrument according to the manual to prolong its service life. "Just a light press, the test will be completed automatically" is the operating characteristics of this instrument.

If you are satisfied with this instrument, please tell your colleagues; if you are not satisfied with this instrument, please call (0312) 6775656 to tell you to serve you at all times-Baoding Huazheng Electric Manufacturing Co., Ltd., our company will definitely make you satisfied !

## Contents

I. Foreword.....	1
II. Security Measures.....	1
III. Testable Parameters.....	2
IV. Performance Features.....	2
V. Technical Indicators.....	3
VI. Measuring Method And Principle.....	5
VII. Wiring Methods For Common Devices.....	6
VIII. Introduction To Instrument Functions.....	9
IX. Operation Steps Of Instrument.....	10
X. Tips For The Instrument.....	12
XI. Notes For Site Test.....	13
XII. Instrument Detection.....	15
XIII. Discussion On Variable Frequency Measurement.....	15
XIV. Packing List.....	17

## **I. Foreword**

Dielectric loss measurement is a basic method in insulation test and effectively detect damp, degradation and partial defect of insulation of electrical equipment. This method is widely used in electric manufacturing, electric equipment installation, connection and preventive test. Measurement on dielectric loss of transformer, mutual inductor, reactor, capacitor, bushing and arrester is the most basic method to test their insulation property.\*\*\*\* fully-automatic anti-interference dielectric loss tester breaks through the traditional bridge testing method and adopts variable frequency power technology, single chip and modernized electrical technology to carry out automatic frequency shift, analog-to-digital conversion and data computing. It features strong anti-interference capacity, high test speed, high precision, automatic digitization and easy operation. It adopts high-power switching power supply, which outputs 45Hz and 55Hz pure sine wave and automatically increase the voltage to a maximum value 10 KV. It can filter 50Hz interference automatically, and it is applicable to the site test of substation and other places with large electromagnetic interference. This methods is extensively applied in dielectric loss measurement of transformer, mutual inductor, reactor, bushing, capacitor, arrester and others equipments in power industry.

## **II. Security Measures**

1. Please read this manual carefully before using the instrument.
2. Operator of this instrument should be equipped with the knowledge of using general electrical equipment and instrument.
3. This instrument is suitable for both indoor and outdoor use and should be kept away from rainwater, corrosive gas, thick dust, direct sunshine and so on.
4. The instrument should avoid severe vibration.
5. Maintenance, care and regulation of the instrument should be conducted by professionals.
6. Connect the grounding terminal of the instrument with the ground by a ground wire

in a reliable way before any wiring.

7. As the testing equipment may produce HV, the testing personnel should abide by the safety operation specification strictly to prevent others from contacting high-voltage component and circuit. Personnel who are directly engaged in testing must exactly understand the high-voltage test circuit as well as key points for operation. People other than testing personnel must keep away from HV testing area and the testing area should be clearly marked with fence, rope or warning sign.

8. Adjustment and maintenance of the instrument should be conducted in a no power-up state. If power-up is required, the operator must be familiar with the high-voltage hazardous components of this instrument very well.

9. In case that the fuse is broken, replace it with another identical fuse. Any fuses of different models or direct use in short circuit is forbidden.

10. In case that the instrument breaks down, turn the power off and check it one minute later.

### **III. Testable Parameters**

The instrument can test the following parameters and display them in figure:

Capacitance value of tested article CX is in pF or nF, 1nF=1,000pF.

Dielectric loss value of tested article  $\text{tg}\delta$  is displayed with %.

### **IV. Performance Features**

1. The instrument adopts complex number current method to measure capacitance, dielectric loss and other parameters. The measured result is highly accurate and it is easy to realize automatic measurement.

2. The instrument adopts variable frequency technology to eliminate 50Hz/60Hz power frequency interference. So a reliable data will be reachable even under the strong electromagnetic interference.

3. The instrument adopts large screen LCD . In the process of testing, Chinese menu

prompt is visualized and easy to operate.

4. The instrument is easy to operate and the measuring process is controlled by microprocessor. Once a suitable measuring method is selected, the data measurement will complete automatically under the control of microprocessor.

5. The instrument is designed to be an integrated model with reference capacitor and HV power supply in it, enables site test measurement and reduces site wiring.

7. The instrument is equipped with CVT testing function, which can achieve CVT self-exciting testing without external accessories and measure the capacitance and dielectric loss of C1 and C2 by at a time.

8. GST measurement adopts ivddv technology and avoids unstable data provided by previous GST measurement.

9. The instrument provides low voltage shell function of GST. When the bus of 220kV CVT is grounded, dielectric loss measurement can be conducted for C11 without removing 10 kV GST.

10. The instrument has a function of measuring high-voltage dielectric loss. It can carry out dielectric loss test with over 10kV with the help of voltage transformer or series resonance.

12. The instrument has a ground-fault protection function. In case that the instrument is not grounded or grounded incorrectly, the instrument will refuse to enter into normal procedure and output HV. As for the over-current protection function, it will protect the instrument from damage when the tested article is in a short circuit or breakdowns.

13. The instrument has a function of electric shock protection. When the instrument operator suffers an electric shock due to incaution, the instrument will cut off the HV immediately and thus ensure the security of operator.

## **V. Technical Indicators**

Accuracy: Cx:  $\pm (\text{reading} \times 1\% + 1\text{pF})$

tgδ:  $\pm (\text{reading} \times 1\% + 0.00040)$

Anti-interference: Variable frequency anti-interference, the above accuracy can be reached under 200% interference.

Capacitance range: Internal HV: 3pF~60000pF/10kV 60pF~1μF/0.5kV

External HV: 3pF~1.5μF/10kV 60pF~30μF/0.5kV

Resolution: Maximum 0.001pF, 4 valid figures.

tgδ range: unlimited, 0.001% resolution, automatic identification for capacitance, inductance and resistance of three tested articles.

Test current range: 10μA~1A

Internal HV: Set voltage range: 0.5~10kV

Maximum output current: 200mA

Buck-bust method: continuous stepless regulation

Test frequency: 45, 50, 55 single frequency

45/55Hz automatic dual variable frequency

Frequency accuracy: ±0.01Hz

External HV: In case of UST, maximum test current is 1A, and power frequency or variable frequency is 40-70Hz

In case of GST, maximum test current is 10kV/1A, and power frequency or variable frequency is 40-70Hz

CVT self-exciting low voltage output: Output voltage 3~50V, output current 3~30A

Measuring duration: About 40s, depending on measuring method

Input power supply: 180V~270VAC, 50Hz/60Hz±1%, supplied by alternating current or generator

Printer: WH-A7 mini-type thermal printer

Environment temperature: -10℃~50℃

Relative humidity: <90%

Overall dimension: 460×360×350mm

Weight: 28kg

## VI. Measuring Method And Principle

There are two measuring methods according to whether tested article is grounded, namely UST measurement and GST measurement. Their principles are shown in Diagram 1.

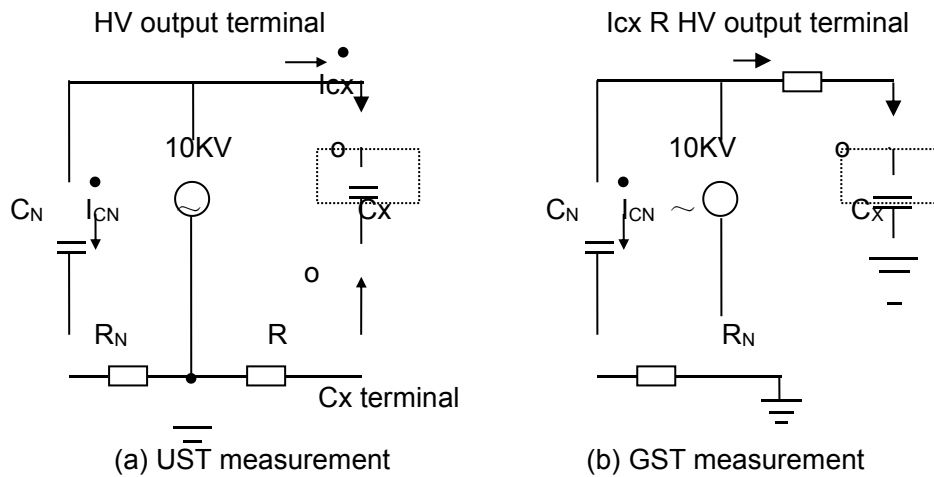
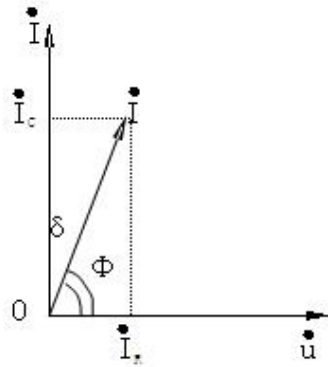

Diagram 1

By the side of high-voltage power supply 10kV, the HV is distributed into two branches, one of which is supplied to internal reference capacitor  $C_N$ . Dielectric loss of this capacitor is very small and can be basically ignored, namely pure capacitive current.  $I_{CN}$  works as the basic standard of capacitive current. By the side of  $C_X$  tested article, the measured current  $I_{CX}$  flows to the instrument through sampling resistor  $R$ .  $I_{CX}$  can be decomposed into horizontal component and vertical component, as shown in Diagram 2 and  $\tan\delta$  value can be determined by calculating ratio of horizontal component and vertical component.

$C_X$  in Diagram 1(a) is ungrounded tested article. Current of tested article  $I_{CX}$  flows to sampling resistor  $R$  though its terminal, then the total current value is determined.  $C_X$  in Diagram 1(b) is grounded product, and  $C_X$  terminal in the instrument is grounded directly.  $I_{CX}$  flows from HV terminal of tested article to sampling resistor in the instrument, thus the total current value is determined.



(a) Current vector method

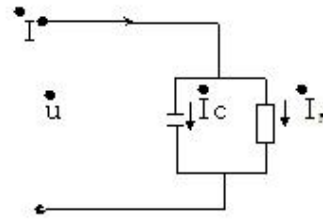

(b) Equivalent circuit of tested article

Diagram 2

## VII. Wiring Methods For Common Devices

### 1. Explanation for instrument leading-out terminal

HV — HV terminal of measuring leading cable of instrument (**with dangerous voltage**).

CX — Input terminal of measured current in case of UST.

Ground terminal of instrument, connected with the ground in a reliable way when using.

### 2. Reference wiring

2.1 UST, internal reference capacitor, internal HV (conventional UST):

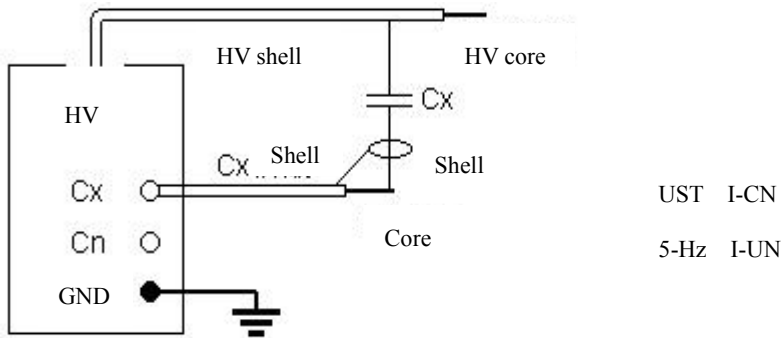

2.2 GST, internal reference capacitor, internal HV (conventional GST )

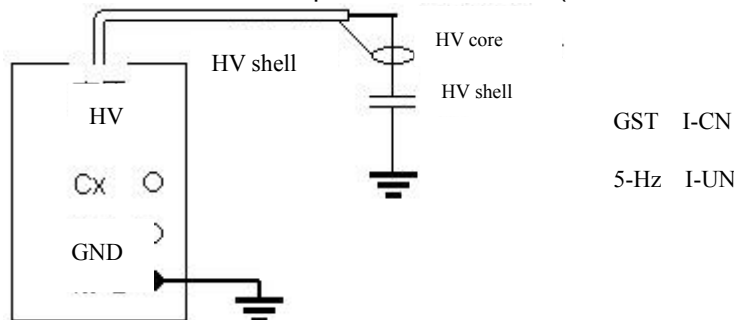

2.3 UST, external reference capacitor, internal HV;

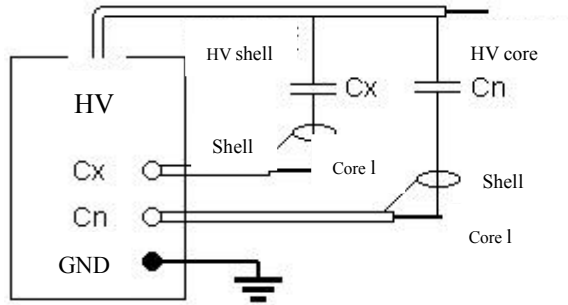

UST E-CN  
5-Hz I-UN

2.4 GST, external reference capacitor, internal HV;

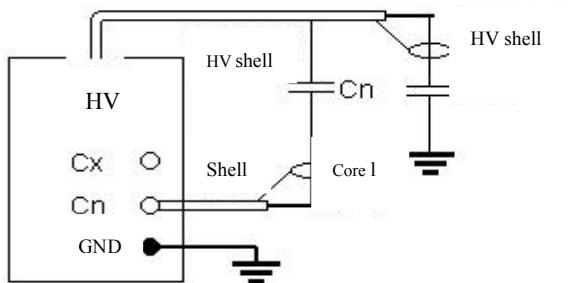

GST E-CN  
5-Hz I-UN

2.5 UST, internal reference capacitor, external HV:

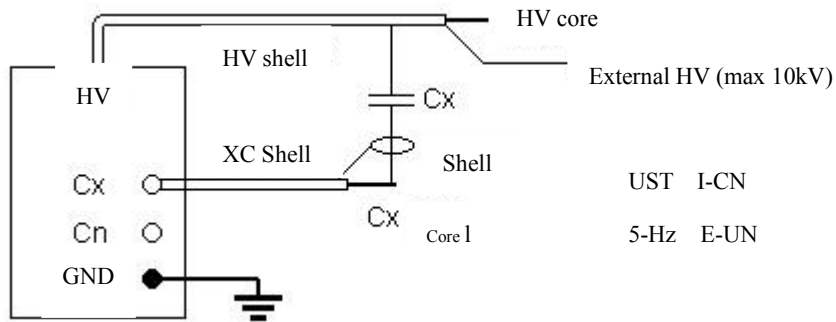

UST I-CN  
5-Hz E-UN

2.6 GST, internal reference capacitor, external HV:

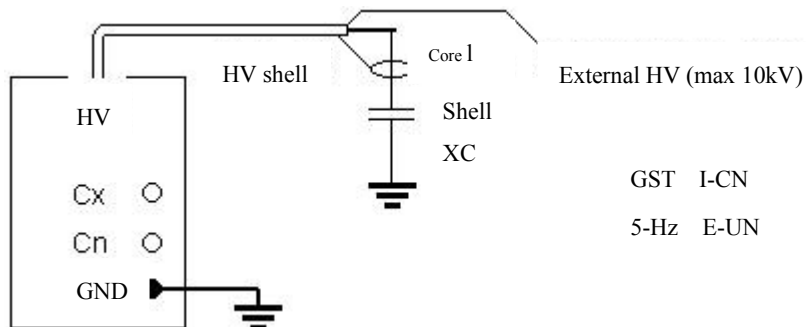

GST I-CN  
5-Hz E-UN

2.7 UST, external reference capacitor, external HV( HV dielectric loss)

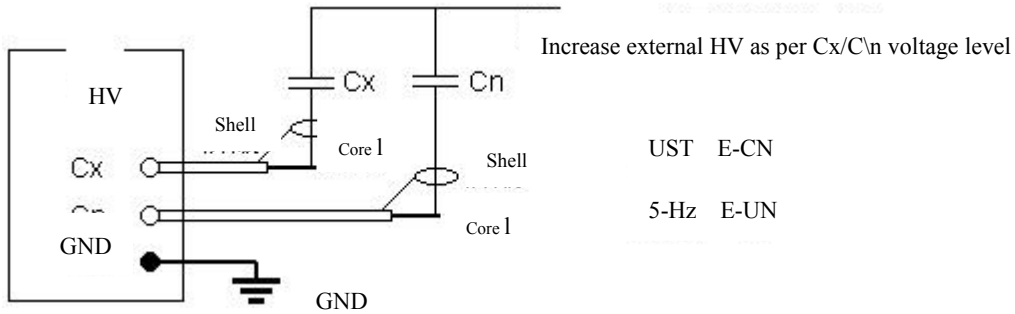

2.8 GST, external reference capacitor, external HV:

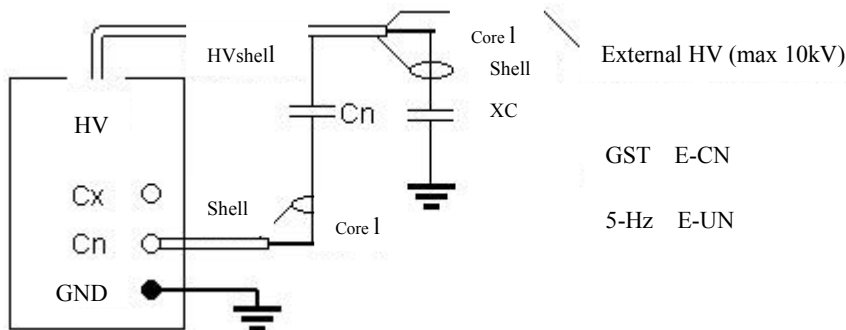

2.9 CVT self-exciting measurement

Wiring of CVT self-exciting measurement is as per the following diagram. If  $C_1$  is single-section capacitor, the bus should not be grounded. If  $C_1$  is multiple-section capacitor, it can be grounded.  $C_{11}$  and  $C_{12}$  can adopt conventional UST and GST measurements, but for  $C_{13}$  for  $C_2$ , self-exciting measurement is advisable.

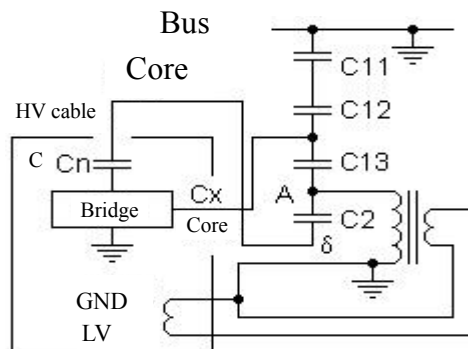

When adopting CVT self-exciting measurement, the instrument should measure  $C_1$  firstly and then  $C_2$  with the method of lead measurement and correct impact of voltage division automatically. It should be noticed that the HV cable should be hung in the air;

otherwise additional dielectric loss to the ground will cause errors. It is feasible to connect the HV socket and CVT with a fine cable and suspends them. **It is strongly recommended that black Cx cable should be used to connect with the HV socket.**

### 3. Additional function

3.1 When the cursor is at voltage: **10kV**, press “OK” key and an  icon will appear on left bottom of instrument screen. It means that it will print automatically after testing. Press the OK key again, the icon will disappear. It means that it must be printed manually after testing.

3.2 When the cursor is at **variable frequency**, under the circumstance of GST, I-CN and I-UN, press OK key and an  icon will appear on right bottom of instrument screen. It means that the reverse wiring low voltage shell testing will begin. Press the OK key again the icon will disappear. It means that GST low voltage shell is removed.



3.3 When the cursor is at **GST**, press OK key means testing the printer and change paper.

3.4 When the cursor is at **start**, press DOWN key means taking out the stored data.

3.5 After finishing test, press **DOWN key** means storing test data.

## VIII. Introduction To Instrument Functions

The instrument panel is as shown in Diagram 9:

1. Printer——Printing measurement data.
2. Display——128×6 dot-matrix LCD, displaying menu and all kinds of prompt message and measurement information.
3.  key——Selecting menu item; the selected item will be displayed in reversed font.
4.  key——Change menu item and adopt circulating rolling method.
5.  key——Chang menu item and adopt circulating rolling method.
6. OK key——Press this key on “test” option to enter into testing.
7. Power switch——Power on and off the entire power supply..

8. Power jack——AC 220V±10%, 50±1Hz power input port with fuse installed.
9. Self-exciting current output terminal——Measuring special terminal for CVT.
10. Ground ——Terminal of ground wire.
11. C<sub>N</sub> socket——input terminal for external reference capacitor. In case of internal reference is adopted, this terminal will be idle.
12. C<sub>X</sub> socket——Input terminal for measuring signal. Connect it with a special low voltage cable in case of UST. It is a single shielded cable with a length of 15 m and equipped with a particular alligator clip. The cable is connected with the lower terminal of tested article. In case of GST, this terminal will not be occupied.
13. HV socket——HV leading-out terminal. It is connected to HV terminal of tested article with a HV cable. The output voltage is 10kv.
14. RS-232 interface. It is connected with computer for the purpose of uploading data.

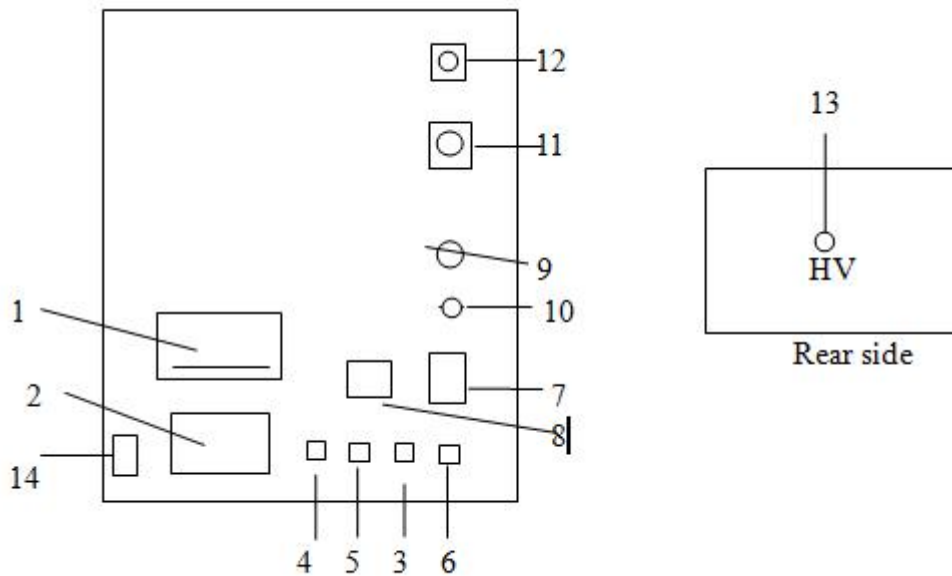

Diagram 9

## IX. Operation Steps Of Instrument

### 1. Preparation for measurement:

1) Connect one end of ground wire with ground pole of instrument and the other end with reliable ground in order to ensure instrument casing is at the ground potential.

2) **UST:** Insert the HV cable plug in the back door HV socket and fix the big red



clamp on the other end on the HV terminal lead. Suspend the small black clamp or clamp it on the big red clamp. Insert the C<sub>x</sub> low voltage cable in the C<sub>x</sub> socket. Fix the lower terminal of tested article by the red clamp on the other end, suspend the black clamp or connect it with the shield.

3) **GST**: Insert the HV cable plug in the back door HV socket and fix the big red clamp on the other end on the HV terminal lead. Suspend the small red clamp or connect it with shield. C<sub>x</sub> socket is needless.

2. Turn on power switch, the instrument will begin self-checking. If the result comes to be good, LCD will display a Chinese menu as shown in Diagram 10.

3. Menu option:

1) Move the cursor to each menu option by  key, and indicate them in cycle. The selected option will be displayed in reverse font. Procedure of selecting key is as shown in Diagram 11.

2) For the items that the cursor points to, the menus can be changed by   keys and indicated in cycle. The procedure is as shown in Diagram 12.

3) After changing the menu to correspond to testing requirement, press the selection key to select for the next item.

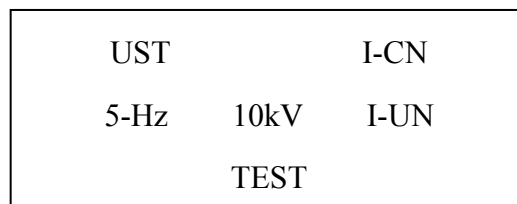
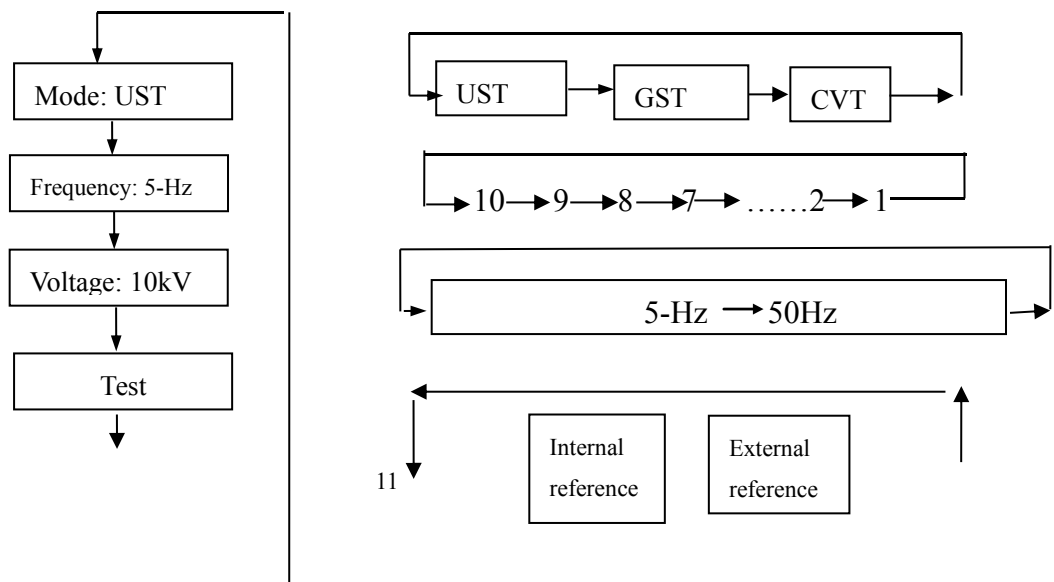

Diagram 10



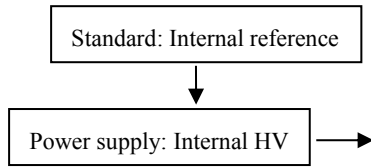

Diagram 11

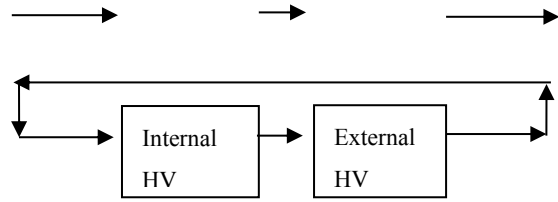

Diagram 12

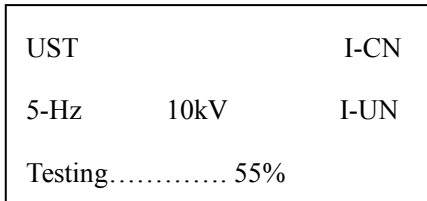

Diagram 13

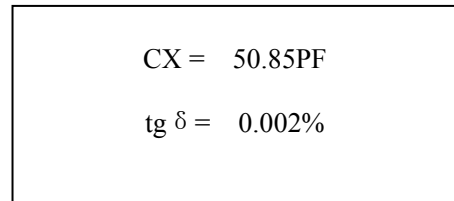

Diagram 14

4. Testing: Power on, and place the cursor on testing item. Press OK key for about 5 seconds to start testing. It will show menus in testing process, as shown in Diagram 13 (UST, 5-Hz). When testing progress is up to 100%, the test is completed and it will display the test result as shown in Diagram 14. At this moment, the cursor will point to the printer icon and press OK key to print the report. The test result has the following meaning:

tgδ: Loss factor of tested article tgδ value.

CX: Measured capacitance value

V: Applied voltage value

I: Current flowing through the tested article

F1, F2: Testing frequencies

After completing printing, turn off the power switch and the test comes to an end.

## X. Tips For The Instrument

1. When the cursor is at **voltage: 10kV**, press “OK” key and an  icon will appear on left bottom of instrument screen. It means that it will print automatically after testing. Press the OK key again, the icon will disappear. It means that it must be printed manually after testing.

2. When the cursor is at **variable frequency**, under the circumstance of GST, I-CN and I-UN, press OK key, and an  icon will appear on right bottom of instrument

screen. It means that the reverse wiring low voltage shell testing will begin. Press the OK key again the icon will disappear. It means that GST low voltage shell is removed.

3. When the cursor is at **wiring: In a GST mode**, to press **OK** key means testing the printer and changing paper.

4. When the cursor is at **start**, to press **DOWN** key means taking out the stored data.

5. After finishing test, pressing **DOWN key** means storing test data.

## **XI. Notes For Site Test**

If the test data is obviously unreasonable when using it, it may be caused by:

### 1. Poor contact of hook

Hook and tested article should keep in good contact when the hook is used to connect tested article in site measurement, otherwise the contact point may discharge and thus lead to wild data fluctuation. Too thick oxide coating of drainage cable or cable movement caused by wind may lead to poor contact.

### 2. Poor ground connection

Poor ground connection may cause instrument protection or wild data fluctuation. Scrape the paint and rust at ground point and guarantee against any resistance grounding.

3. Direct measurement of CVT or measuring electromagnetic PT with the method of end shell

Negative value phenomena of dielectric loss may occur when the next section coupled capacitor of CVT is directly measured. So self-exciting method will be preferred

In case that negative value of dielectric loss occurs as the result of "T-type network interference" caused by damp when measuring electromagnetic PT with the method of end shell, dry the triple petticoat insulator and wiring terminal block under it. Alternatively, adopt conventional method or increasing end voltage measurement method.

### 4. High air humidity

If the air humidity exceeds the standard and results in abnormal increase (decrease or

even negative value) of measurement result and its instability, add a shell if necessary. However, adding shell by human factor may change the electric-field distribution of tested article. So this method is debatable and should be subject to the related regulations.

#### 5. Power supply from generator

In case that the input frequency is unstable when generator works, adopt 50Hz mode.

#### 6. Test cable

Since long term use may result in hidden disconnection of test cable, short circuit of core and shield or poor contact of plug, user should maintain the test cable periodically.

When testing the tested article with reference capacitance, the fully shielded plug should be used to eliminate the impact of additional stray capacitance. If not, the instrument accuracy cannot be realized.

When measuring CVT with self-exciting method, suspend the non-dedicated HV cable, otherwise the additional stray capacitance and dielectric loss to the ground may cause errors.

#### 7. Operating mode selection

Select a correct operating mode for measurement after wiring (UST, GST and CVT), any mistake is not allowed. Particularly select variable frequency anti-interference mode under interference environment.

#### 8. Impact of testing method

For the reason that dielectric loss measurement may vary from different methods, it is important to distinguish test method error from instrument errors. When faults appear, firstly check wiring and then determine whether the instrument goes wrong.

#### 9. Instrument fault

Detect the disconnection status of test cable or short circuit of core and shield with a multimeter; determine whether 220V input power is too high or too low and whether grounding is in good contact.

Measure the reference capacitor or tested capacitor with known capacitor and dielectric loss. If the result turns out to be correct, then it can be concluded that the

instrument has no problem.

Pull off all test cables to conduct voltage increase in an idle state. If the instrument fails to work normally, it has gone wrong.

Measure low voltage output after starting CVT measurement, 2 ~ 5V voltage should appear, otherwise the instrument has gone wrong.

## XII. Instrument Detection

### 1. Detect with reference loss tester

Connect the reference loss tester with a shielded cable with plug. If the accuracy of loss tester is unwarranted, take a comparison method for detection. It is suggested to take 2801 electric bridge or other precision electric bridge as a referenced standard. Instrument should select “internal reference” and “RC cascade tested article” and power frequency 50Hz or 50Hz with regard to frequency mode.

2. Detect with QSJ3: Connect QSJ3 with shielded cable with plug, select “UST/E-CN/E-UN measurement, current ratio is represented by  $C_x$ :  $C_n$  and set an appropriate value for  $C_n$ .

### 3. Anti-interference capacity

Set a loop circuit and inject quantified interference current to the instrument.

Note:

1) Please be noted that the loop circuit may be a part of tested article.

2) As the instrument starts, the 220V power supply circuit may produce a measurement frequency component. If the frequency component enters into the instrument by interference current, then the anti-interference capacity of instrument cannot be measured.

3) It is not advised to apply interference with an almost HV conductor as it may result in close range point discharge. This kind of discharge resistance is nonlinear resistance, which is likely to produce co-channel interference.

## XIII. Discussion On Variable Frequency Measurement

### 1. Variable frequency measurement

An accurate and reliable result may be reached by a variable frequency even if the interference is extremely serious. For example, if 55Hz measurement is adopted, only 55Hz signal is allowed by measurement system and 50Hz interference signal is restrained effectively. The reason lies in that the measurement system is likely to distinguish different frequencies and the effect of selective frequency measurement can be explained by the following simple calculation:

When a sine wave superimposes on another one, whose frequency is twice as that of the former, the high frequency is interference and its amplitude is ten times as much as that of low frequency.

$$Y=1.234\sin(x+5.678^\circ)+12.34\sin(2x+87.65^\circ)$$

Supposing that  $x=0/90/180/270^\circ$ , 4 measurement valued will be available.

$$Y_0=12.4517, Y_1= -11.1017, Y_2=12.2075, Y_3= -13.5576,$$

Calculating:  $A=Y_1 - Y_3=2.4559$ ,  $B=Y_0 - Y_2=0.2442$ , then:

$$\varphi=\text{tg}^{-1}(B/A)=5.678^\circ \quad V= \sqrt{A^2+B^2} / 2=1.234$$

This is just the phase and amplitude of low frequency and the interference is restrained. There are as much as tens of thousands of measurement points on actual wave forms. It is a very demanding calculation and the result reflects the overall features of waveform.

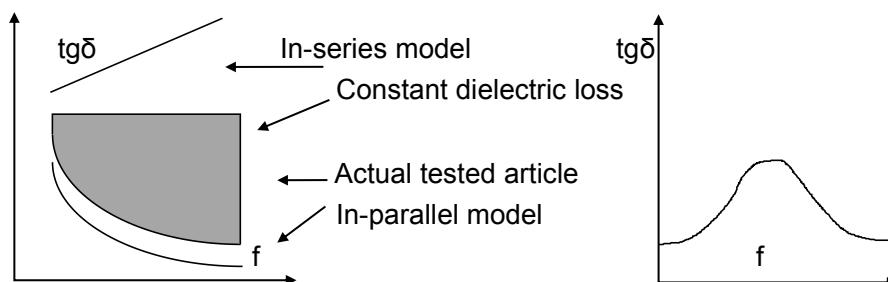

Low frequency dielectric loss curve (<1kHz)

High frequency dielectric loss curve or

low frequency circuit resonance

## 2. Relationship between frequency and dielectric loss

The dielectric loss can be divided into two ideal models: RC in series and RC in

parallel: RC in series  $\text{tg}\delta=2\pi fRC$ ; RC in parallel  $\text{tg}\delta=1/(2\pi fRC)$ .  $\text{tg}\delta$  is in a direct or inverse ratio as the frequency  $f$  varies. As shown in diagram,  $f$  makes a great influence on both complete direct ratio model and complete inverse ratio model. However, the actual capacitor is in mixed model composed by various models and influence of  $f$  turns to be smaller under this circumstance.

### 3. Automatic variable frequency and 50Hz equivalent

The instrument takes two measurement points by two sides of interference frequency 50 Hz with the method of automatic variable frequency and then calculates the data under 50 Hz frequency on the basis. No single medium of tested article will induce energy absorption peak under low frequency, leaving out low frequency resonance in multiple-component circuit. Besides, the dielectric loss closing to power frequency will vary monotonously with frequency. Therefore, this kind of measurement will not cause any obvious errors. Actually, the two dielectric loss values have little difference before averaging, so they are of valuable reference in spite of their uneven values. Currently, variable frequency dielectric loss tester has become a conventional instrument for dielectric loss measurement with its excellent anti-interference capacity and well-recognized accuracy.

## XIV. Packing List

No.	Item	Qty
1	Main engine	1
2	Power line	1
3	Ground lead	1
4	Printer paper	1
5	High voltage cable	1
6	CVT cable	2
7	Red test line	1
8	Black test line	1